

INSTRUCTION MANUAL (ATEX)

BExBG05E Flameproof / Increased Safety Xenon Beacons

For use in Flammable Gas and Dust Atmospheres

1) Introduction

The BExBG05E is a second generation flameproof beacon which is certified to the European Standards EN 50014: 1992, EN 50018: 1994 and EN 50019 : 1994, the Combustible Dust standard EN 50281-1-1: 1999 and meets the requirements of the ATEX directive 94/9/EC. The beacon produces synchronised visual warning signals and can be used in hazardous areas where potentially flammable gas and dust atmospheres may be present. The BExBG05E has an output level of 5 joules and can be used in Zone 1 and Zone 2 areas with gases in groups IIA, IIB and IIC and Temperature Classifications of T1, T2, T3, T4 and T5. The unit can also be used in a temperature classification T6, if the upper ambient temperature is restricted to +40°C. The unit can be used in Zone 21 and Zone 22 areas for combustible dusts and has an IP rating of IP 66 and a surface temperature rating of T100°C or T85°C if the upper ambient temperature is restricted to +40°C.

2) Marking

All units have a rating label, which carries the following important information:-

Unit Type No. BExBG05E

Input Voltage: DC Units 12V or 24V or 48V
AC Units 230V or 115V

Code: EEx de IIC T5 (Tamb. -50 to +55°C)
EEx de IIC T6 (Tamb. -50 to +40°C)

IP66 T100°C Ta ≤ +55°C
T85°C Ta ≤ +40°C

Certificate No. KEMA 00ATEX2006 X

Epsilon x:
Equipment Group and
Category:

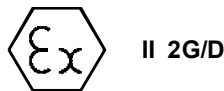

CE Marking
Notified Body No.

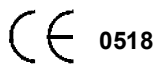

Warnings: DO NOT OPEN WHEN AN EXPLOSIVE
GAS OR DUST ATMOSPHERE IS PRESENT

COVER BOLTS CLASS A4-80

USE HEAT RESISTING CABLES AND CABLE GLANDS
(Rated 95°C) AT AMB. TEMPERATURES OVER 40°C

Year of Construction /
Serial No. i.e. 03 / 1DB43000001

3) Type Approval Standards

The beacons have an EC Type examination certificate issued by KEMA and have been approved to the following standards:-

EN 50014 : 1992 + prA1	General Requirements
EN 50018 : 1994 + prA1 + prA2 + prA3	Flameproof Enclosure 'd'
EN 50019 : 1994 + prA1 + prA2	Increased Safety 'e'
EN 50281-1-1 : 1999	Combustible Dust

4) Installation Requirements

The beacons must be installed in accordance with the latest issues of the relevant parts of the BS EN 60079 specifications or the equivalent IEC specifications – Selection, Installation and maintenance of electrical apparatus for use in potentially explosive atmospheres (other than mining applications or explosive processing and manufacture):-

BS EN 60079-14 : 1997	Electrical Installations in Hazardous Areas (other than mines)
BS EN 60079-10 : 1996	Classification of Hazardous Areas

The installation of the units must also be in accordance with any local codes that may apply and should only be carried out by a competent electrical engineer who has the necessary training.

5) Zones, Gas Group, Category, IP Rating and Temperature Classification

The BExBG05E beacons have been certified EEx de IIC T5 (Tamb. -50 to +55°C) and EEx de IIC T6 (Tamb. -50 to +40°C) for gas and IP66 T100°C Ta ≤ +55°C and T85°C Ta ≤ +40°C for dust. This means that the units can be installed in locations with the following conditions:-

Area Classification Gas:

Zone 1	Explosive gas air mixture likely to occur in normal operation.
Zone 2	Explosive gas air mixture not likely to occur, and if it does, it will only exist for a short time.

Gas Groupings:

Group IIA	Propane
Group IIB	Ethylene
Group IIC	Hydrogen and Acetylene

Temperature Classification:

T1	400° C
T2	300° C
T3	200° C
T4	135° C
T5	100° C

T6	85° C	Amb. +40°C
----	-------	------------

Area Classification Dust:

Zone 21	Explosive dust air mixture likely to occur in normal operation.
Zone 22	Explosive dust air mixture not likely to occur, and if it does, it will only exist for a short time.

IP Rating: IP66 T100°C $T_a \leq +55^\circ\text{C}$
T85°C $T_a \leq +40^\circ\text{C}$

Equipment Category: 2G/D

Ambient Temperature Range: -50°C to $+55^\circ\text{C}$
($T_6 = +40^\circ\text{C}$)

6) Beacon Location and Mounting

The location of the beacons should be made with due regard to the area over which the warning signal must be visible. They should only be fixed to services that can carry the weight of the unit.

The beacons should be securely bolted to a suitable surface using the 7mm diameter boltholes in the stainless steel U shaped mounting bracket (see figure 1). The required angle can be achieved by loosening the two large bracket screws in the side of the unit, which allow adjustment of the beacon in steps of 18° . On completion of the installation the two large bracket adjustment screws on the side of the unit must be fully tightened to ensure that the unit cannot move in service.

SAFETY WARNING:

The flashdome guard must not be removed from the unit at any time.

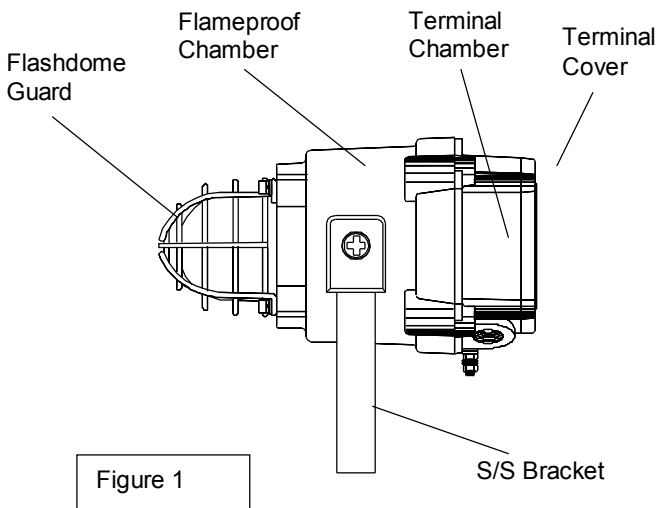

Figure 1

7) Access to the Flameproof Enclosure

For normal operation it will not be necessary to gain access to the flameproof chamber. The only time this will be necessary is when the unit is being set to flip-flop mode or the fitting of an end of line monitoring resistor on DC units. If access is necessary remove the four M6 hexagon socket head screws (see figure 2) and withdraw the flameproof cover taking extreme care not to damage the flameproof joints in the process.

Note the four **M6 screws are Class A4-80 stainless steel and only screws of this category can be used on the beacons**. It is therefore important that these screws and their spring washers are kept in a safe place during installation.

On completion of the output mode setting or the fitting of the end of line resistor, the flameproof joints should be inspected to ensure that they are clean and that they have not been damaged. Also check that the earth bonding wire between the two casting sections is secure and that the 'O' ring seal is in place. When replacing the terminal chamber section casting, ensure that it is square with the flameproof chamber casting before inserting. Carefully push the section in place allowing time for the air to be expelled. Only after the section is fully in place should the four M6 Stainless Steel A4-80 cover bolts and their spring washers be inserted and tightened down. If the section jams while it is being inserted, carefully remove it and try again. Never use the M6 cover bolts to force the cover into position.

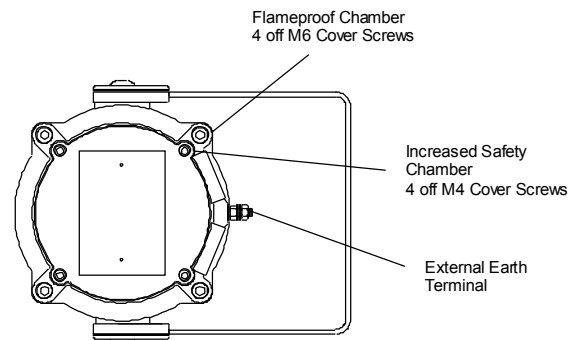

Figure 2

8) Access to the Increased Safety Terminal Chamber

To connect the input cables to the beacon it is necessary to remove the terminal cover to gain access to the termination chamber. To achieve this remove the four M4 hexagon socket head screws (see figure 2). The four M4 screws and their spring washers are grade A4 stainless steel and they should be kept in a safe place during installation. Before replacing the terminal cover ensure that the earth bonding wire between the two castings is secure and that the 'O' ring seal is in place. Insert the four M4 hexagon screws and their spring washers and tighten them down.

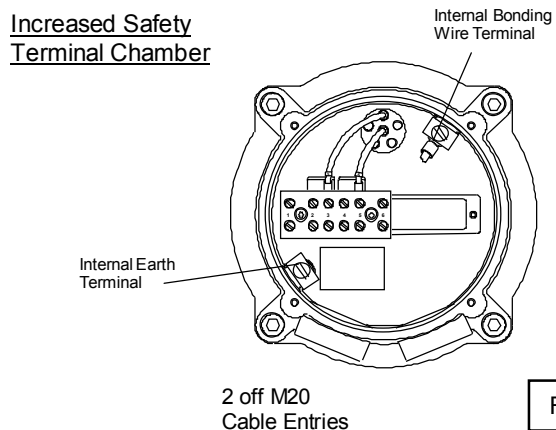

Figure 3

9) Power Supply Selection

It is important that a suitable power supply is used to run the beacons. The power supply selected must have the necessary capacity to provide the input current to all of the beacons connected to the system.

The following table shows the input current taken by the various beacons:-

Unit Type	Nominal I/P Voltage	Input Current	Max. I/P Volts
BExBG05E	12V DC	750mA	15V
BExBG05E	24V DC	300mA	30V
BExBG05E	48V DC	180mA	58V
BExBG05E	230V AC	55mA	253V
BExBG05E	115V AC	140mA	126V

The input current will vary according to the voltage input level. The current levels shown above are for nominal input voltage. The 12V, 24V and 48V DC units have a converter circuit and therefore the input current level will decrease slightly as the input voltage is increased and will increase slightly as the input voltage is reduced.

The above table also shows the maximum voltages at which the beacons can be operated.

10) Cable Selection

When selecting the cable size consideration must be given to the input current that each unit draws (see table above), the number of beacons on the line and the length of the cable runs. The cable size selected must have the necessary capacity to provide the input current to all of the beacons connected to the line.

SAFETY WARNING: If the BExBG05E beacons are used at high ambient temperatures, i.e. over +40°C, then the cable entry temperature may exceed +70°C and therefore suitable heat resisting cables must be used, with a rated service temperature of at least 95°C.

11) Earthing

Both AC and DC beacon units must be connected to a good quality earth. The units are provided with internal and external earthing terminals which are both located on the terminal chamber section of the unit (see figures 2 and 3).

When using the external earth terminal a cable crimp lug must be used. The cable lug should be located between the two M5 stainless steel flat washers. The M5 stainless steel spring washer must be fixed between the outer flat washer and the M5 stainless steel nut to ensure that the cable lug is secured against loosening and twisting.

The internal earth bonding wire ensures that a good quality earth is maintained between the flameproof chamber casting and the flameproof cover casting.

12) Cable Glands

The BExBG05E beacons have dual cable gland entries which have an M20 x 1.5 entry. Only cable glands approved for Ex 'e' applications or better (i.e. Ex 'd' applications, provided they have an IP rating of IP 54 or better) can be used. They must be suitable for the type of cable to be used and also meet the

requirements of the Ex equipment installation standard BS EN 60079-14 : 1997.

When only one cable entry is used the other one must be closed with an Ex 'e' blanking plug, which must be suitably approved for the installation requirements.

For combustible dust applications, the cable entry device and blanking elements shall be in type of explosion protection increased safety "e" or flameproof enclosure "d" and shall have an IP 6X rating according to EN 60529.

SAFETY WARNING: If the beacons are used at high ambient temperatures, i.e. over +40°C, then the cable entry temperature may exceed +70°C and therefore suitable heat resisting cable glands must be used, with a rated service temperature of at least 95°C.

13) Cable Connections

The cable connections are made into an EEx e II approved six way terminal block which is located in the Increased Safety Area terminal chamber (see figure 3). See section 8 of this manual for access to the terminal chamber. When wiring into Increased Safety Area terminal enclosures, you are only permitted to connect one wire into each way on the terminal block. Therefore in order that beacons can be connected in a parallel line, the terminal block is fitted with approved connecting combs so that each electrical connection has two terminals in parallel. Terminal No's. 1 and 6 must not be used on either AC or DC units. Cables with a cross-sectional area of up to 4mm² can be connected to the terminal block. Cables that have a small cross-sectional area should be fitted with crimp ferules.

The wiring connections to the beacons are as follows:-

Terminal No's	DC Units	AC Units
2 and 3	-ve	N
4 and 5	+ve	L

14) Synchronised Operation

All BExBG05E beacons that are connected to the same supply line will have a synchronised flash rate at one flash every second.

BExBG05E Flameproof Chamber

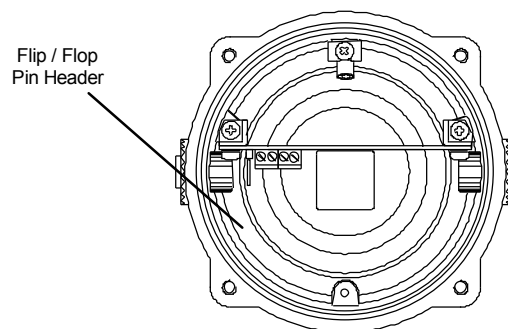

Figure 4

15) Flip-Flop Operation

Two beacons can be mounted close to each other to form a flip-flop operation, where the beacons will flash alternately. To achieve this one beacon must be set so that the first flash is delayed by $\frac{1}{2}$ a second. To set this mode of operation the flameproof chamber must be accessed, (see section 7). The unit is set by fitting a pin header to the flip-flop header pins on the electronics board, i.e. the two header pins are shorted together (see figure 4), on one of the two beacons being used. The two beacons will then flash alternately every $\frac{1}{2}$ a second.

16) End of Line Monitoring (DC Units)

On the BExBG05E DC beacon units, dc reverse line monitoring can be used if required. All DC units have a blocking diode fitted in their supply input lines. An end of line monitoring diode or an end of line monitoring resistor can be connected across the +ve and -ve terminals in the flameproof chamber. **Note monitoring components must not be connected to the terminal block in the Increased Safety terminal chamber.** See section 7 of this instruction manual for access to the flameproof enclosure. If an end of line resistor is used it must have a minimum resistance value of 3k3 ohms and a minimum wattage of 0.5 watts or a minimum resistance value of 500 ohms and a minimum wattage of 2 watts.