

E2xS121 Syrena alarmowa



- Nominalna wartość wyjściowa : 117dB(A) @ 1m +/-3dB
 - 45 alarmowych sygnałów (UKOOA/PFEER)
 - 3 stopnie alarmowe, ustawialne.
 - Kontrola poziomu głośności
 - Automatykna synchronizacja w systemach multisygnałacyjnych
 - 200m efektywnego zasięgu akustycznego @ 1kHz
 - Napięcie: 24vdc(10-30vdc); 48vdc(38-58vdc); 120vac; 230vac
 - Materiał: UL94V0 PPS & ABS
 - Waga: DC: 2.50Kg AC: 3.00Kg
 - ATEX: IP66 & IP67
 - UL: Typ 4, 4X & 13
- ATEX: E2xS121EG
Strefa 2 3G EEx nA nL IIC T4 (Tamb -20°C do +55°C)
Cert: DEMKO 06 ATEX 0421554
 - UL: E2xS121UL
Klasa I, Division 2, Grupy A,B,C,D T3C (160°C) (at +55°C)
Klasa I, Division 2, Grupy A,B,C,D T4 (135°C) (at +40°C)
Klasa II, Division 2, Grupy F & G T6 (85°C)
Klasa III, Division 1, T6 (85°C)
File: E230764
- Duża przestrzeń przyłączeniowa zacisków.
 - ATEX: Dwa otwory M20 ISO na dławice [1 zaślepiiony uszczelką].
 - UL: 1 x 1/2"NPT wejście dławicowe (0.5m)
 - Zapadkowa regulacja uchwytu ze stali nierdzewnej w kształcie litery "U" o obrocie 360°
 - ATEX 'EG' Terminale wej / wyj.
 - ATEX 'EG' Możliwość podłączenia przewodów o przekroju 0.5 to 2.5mm².



Sygnal alarmowy o wysokim stopniu głośności, dobrze słyszalny na tle szumów otoczenia.

Napięcie zasilania i pobór prądu dla E2xS121.

Napięcie;	24vdc	48vdc	120vac	230vac
			50/60Hz	50/60Hz
Zakres napięcia;	10-30v dc	35-58v dc	+/- 10%	+/- 10%
Pobór prądu;	280mA	215mA	142mA	76mA

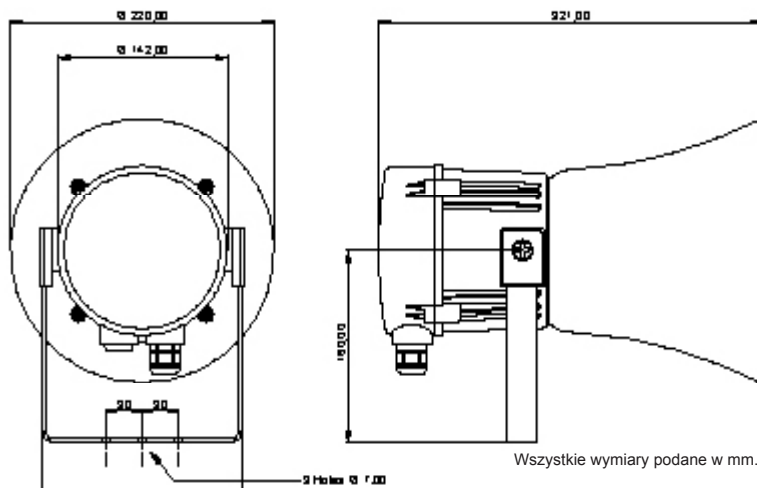

Także dostępne :

E2xCS112-05 Kombinacja syreny z lampą ksenonową.

E2xL15 15w głośnik do systemu PA.

E2x112 Alarmowe syreny

E2xB05 & E2xB10 , 5 i 10 dżuli . Wersje lamp ksenonowych.



Alarm 1 Częstotliwość		dB @ 1m	Alarm 2	Alarm 3
Tone 1	340 Hz Continuous	113dB(A) @ 1m	Tone 2	Tone 5
Tone 2	800/1000Hz @ 0.25 sec Alternating	121dB(A) @ 1m	Tone 17	Tone 5
Tone 3	500/1200Hz @ 0.3Hz 0.5 sec Slow Whoop	121dB(A) @ 1m	Tone 2	Tone 5
Tone 4	800/1000Hz @ 1Hz Sw eeping	121dB(A) @ 1m	Tone 6	Tone 5
Tone 5	2400Hz Continuous	125dB(A) @ 1m	Tone 3	Tone 20
Tone 6	2400/2900Hz @ 7Hz Sw eeping	123dB(A) @ 1m	Tone 7	Tone 5
Tone 7	2400/2900Hz @ 1Hz Sw eeping	125dB(A) @ 1m	Tone 10	Tone 5
Tone 8	500/1200/500Hz @ 0.3Hz Sw eeping	121dB(A) @ 1m	Tone 2	Tone 5
Tone 9	1200/500Hz @ 1Hz - DIN / PFEER P.T.A.P.	121dB(A) @ 1m	Tone 15	Tone 2
Tone 10	2400/2900Hz @ 2Hz Alternating	126dB(A) @ 1m	Tone 7	Tone 5
Tone 11	1000Hz @ 1Hz Intermittent	121dB(A) @ 1m	Tone 2	Tone 5
Tone 12	800/1000Hz @ 0.875Hz Alternating	121dB(A) @ 1m	Tone 4	Tone 5
Tone 13	2400Hz @ 1Hz Intermittent	125dB(A) @ 1m	Tone 15	Tone 5
Tone 14	800Hz 0.25sec on, 1 sec off Intermittent	120dB(A) @ 1m	Tone 4	Tone 5
Tone 15	800Hz Continuous	120dB(A) @ 1m	Tone 2	Tone 5
Tone 16	660Hz 150mS on, 150mS off Intermittent	118dB(A) @ 1m	Tone 18	Tone 5
Tone 17	544Hz (100mS)/440Hz (400mS) - NF S 32-001	117dB(A) @ 1m	Tone 2	Tone 27
Tone 18	660Hz 1.8sec on, 1.8sec off Intermittent	118dB(A) @ 1m	Tone 2	Tone 5
Tone 19	1.4KHz-1.6KHz 1s, 1.6KHz-1.4KHz 0.5s -NFC48-265	126dB(A) @ 1m	Tone 2	Tone 5
Tone 20	660Hz Continuous	118dB(A) @ 1m	Tone 2	Tone 5
Tone 21	554Hz/440Hz @ 1Hz Alternating	118dB(A) @ 1m	Tone 2	Tone 5
Tone 22	544Hz @ 0.875 sec. Intermittent	118dB(A) @ 1m	Tone 2	Tone 5
Tone 23	800Hz @ 2Hz Intermittent	120dB(A) @ 1m	Tone 6	Tone 5
Tone 24	800/1000Hz @ 50Hz Sw eeping	120dB(A) @ 1m	Tone 29	Tone 5
Tone 25	2400/2900Hz @ 50Hz Sw eeping	124dB(A) @ 1m	Tone 29	Tone 5
Tone 26	Bell	118dB(A) @ 1m	Tone 2	Tone 15
Tone 27	554Hz Continuous	117dB(A) @ 1m	Tone 26	Tone 5
Tone 28	440Hz Continuous	117dB(A) @ 1m	Tone 2	Tone 5
Tone 29	800/1000Hz @ 7Hz Sw eeping	121dB(A) @ 1m	Tone 7	Tone 5
Tone 30	300Hz Continuous	114dB(A) @ 1m	Tone 2	Tone 5
Tone 31	660/1200Hz @ 1Hz Sw eeping	121dB(A) @ 1m	Tone 26	Tone 5
Tone 32	Two tone chime.	118dB(A) @ 1m	Tone 26	Tone 15
Tone 33	745Hz @ 1Hz Intermittent	116dB(A) @ 1m	Tone 2	Tone 5
Tone 34	1000 & 2000Hz @ 0.5 sec Alternating - Singapore	121dB(A) @ 1m	Tone 38	Tone 45
Tone 35	420Hz @ 0.625 sec Australian Alert	118dB(A) @ 1m	Tone 36	Tone 5
Tone 36	500-1200Hz 3.75sec /0.25sec. Australian Evac.	121dB(A) @ 1m	Tone 35	Tone 5
Tone 37	1000Hz Continuous - PFEER Toxic Gas	121dB(A) @ 1m	Tone 9	Tone 45
Tone 38	2000Hz Continuous	122dB(A) @ 1m	Tone 34	Tone 45
Tone 39	800Hz 0.25sec on, 1 sec off Intermittent	120dB(A) @ 1m	Tone 23	Tone 17
Tone 40	544Hz (100mS)/440Hz (400mS) - NF S 32-001	121dB(A) @ 1m	Tone 31	Tone 27
Tone 41	Motor Siren - slow rise to 1200 Hz	122dB(A) @ 1m	Tone 2	Tone 5
Tone 42	Motor Siren - slow rise to 800 Hz	121dB(A) @ 1m	Tone 2	Tone 5
Tone 43	1200 Hz Continuous	122dB(A) @ 1m	Tone 2	Tone 5
Tone 44	Motor Siren - slow rise to 2400 Hz	124dB(A) @ 1m	Tone 2	Tone 5
Tone 45	1KHz 1s on, 1s off Intermittent - PFEER Gen. Alarm	121dB(A) @ 1m	Tone 38	Tone 34

Uwaga: SPL odczytywane jest przy nominalnym poziomie zasilania, typowo +/- 3dB i jest to wartość szacunkowa. Przy zasilaniu urz dzeń 10-30vdc następuje spadek SPL o 5 dB.

Konfiguracja urz adze DC.

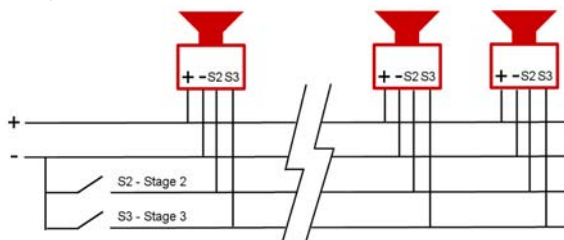

Konfiguracja urz adze AC.

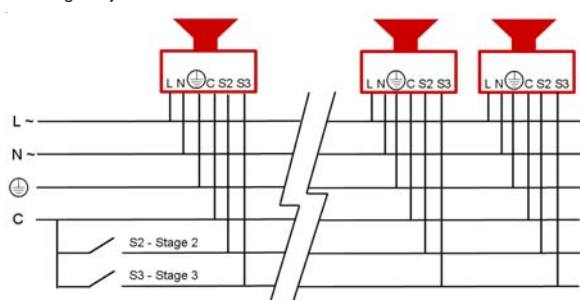

Kod oznaczeń:

E2xS121	UL	24DC
Produkt E2xS121	Typ EG UL	Napi cie zasilania 24DC 48DC 115AC 230AC